

INSTRUCTION MANUAL

PNEUMATIC BELT SANDER

Please read this manual carefully before you attempt to use your tool so that you may use it properly and safely.

BELTON Model B-10CL, B-20CL, B-30CL PROFESSIONAL TOOL

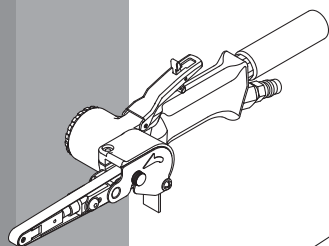

B-10CL

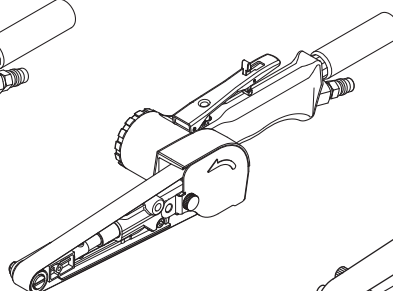

B-20CL

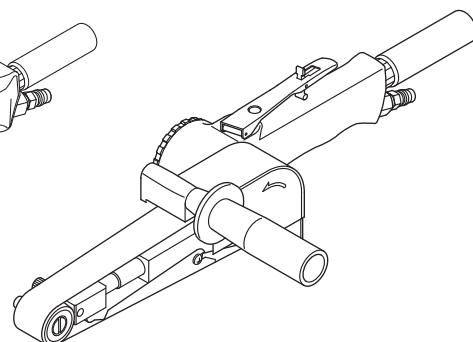

B-30CL

Specifications

Model		B-10CL	B-20CL	B-30CL
Maximum Operating Pressure	MPa	0.6		
Air Consumption (No Load)	m ³ /min	0.4	0.48	0.82
Rated Speed (No Load)	min ⁻¹	17000	18000	15000
Standard Belt Size	mm	10x330 (25/64"x13")	20x520 (25/32"x20-15/32")	30x540 (1-3/16"x21-17/64")
Mass (Weight)	kg	0.9	1.6	2.4
Sound Pressure Level [Uncertainty K]	dB(A)	78 [≤ 2.0]	81 [≤ 2.0]	86 [≤ 2.0]
Sound Power Level [Uncertainty K]	dB(A)	89 [≤ 2.0]	92 [≤ 2.0]	97 [≤ 2.0]
Vibration Level [Uncertainty K]	m/s ²	≤ 2.5 (1.2 [0.75])	≤ 2.5 (1.32 [0.19])	Grip: ≤ 2.5 (0.56 [0.17])
				Sub handle: ≤ 2.5 (1.88 [0.3])
Thread Size of Air Inlet		Rc 1/4		

The specifications and configurations contained in this document are subject to change without prior notice due to improvements we are making day in, day out.



NITTO KOHKI

Manufactured by :

NITTO KOHKI Co., Ltd.

9-4, NAKAIKEGAMI
2-CHOME, OHTA-KU,
TOKYO, 146-8555, JAPAN

Tel : +81-3-3755-1111

Fax : +81-3-3753-8791

Keep the manual handy – so you can use it whenever necessary.

Original Instructions

Thank you very much for your purchase of this **Nitto Kohki product**.

Before using your tool, please read this manual carefully so that you may use it properly to get the most out of it.

Please keep the manual handy - so you can use it whenever necessary.

- **English** : Please ask your dealer or distributor for instruction manual in local language(s).
- **German** : Bitte fragen Sie Ihren Händler nach eine Betriebsanleitung in Landessprache.
- **French** : S'il vous plait, veuillez demandez à votre fournisseur de manuel instruction en langue locale.
- **Spanish** : Por favor, contacte con su distribuidor para el manual de instrucciones en español.
- **Portuguese** : Por favor pessa ao seo agente ou distribuidor o manual de instrucces ih linguagen local.
- **Italian** : Per Manuale Istruzioni in lingua locale Vi preghiamo di rivolgervi al rivenditore o distributore.
- **Dutch** : Vraag uw handelaar om een nederladstalige gebruiksaanwijzing.
- **Swedish** : Be er lokala Åtreförsäljare eller distributör om manualer på svenska.
- **Danish** : Venligst henvend Dem til den danske distributør for instructions manualer.
- **Polish** : Proszę pytać swojego dealera lub dystrybutora o instrukcje obsługi w języku localnym.
- **中文** : 請向當地供應商或經銷商詢問中文使用說明書

CONTENTS	page
IMPORTANT SAFETY INSTRUCTIONS	2
GENERAL: TOOLS	2
GENERAL: PNEUMATIC TOOLS	3
INSTRUCTIONS FOR THIS TOOL	4
1. USAGE	4
2. CHECK THE CONTENTS OF THE PACKAGE	4
3. NAME OF PARTS	5
4. AIR SUPPLY	5
5. PREPARATION	6
6. HOW TO OPERATE THE TOOL	7
7. THREAD SIZE OF HOSE FITTING	9
8. STORAGE AND MAINTENANCE	9
9. ORDERING SERVICE PARTS	9
10. OPTIONAL PARTS	10
11. EXPLODED DIAGRAM: B-10CL.....	11
12. EXPLODED DIAGRAM: B-20CL.....	12
13. EXPLODED DIAGRAM: B-30CL.....	13

PICTOGRAM



Warning: It might be dangerous to operate the tool if the instructions supplied are not followed.



Using this tool improperly could result in serious injury. Read the instruction manual before using.



Always wear suitable eye protection.



Always wear suitable hearing protection.



Always wear respiratory protective equipment (PPE).



Always wear protective gloves for protection of hands from Vibration and Shock

The following Safety notations are used throughout the manual to highlight safety precautions for the user and for the tool.



Warning:

Indicates a potentially hazardous situation which, if not avoided by following the instructions given, could result in death or serious injury.



Caution:

Indicates a potentially hazardous situation which, if not avoided by following the instructions given, could result in injury or material damage.

Please note, however, that failure to observe safety precautions under the “**⚠ Caution**” category could result in a serious occurrence depending on the situation: please observe all safety precautions in the manual.

Caution: Important precautions for tool setup, operation and maintenance.

IMPORTANT SAFETY INSTRUCTIONS

When using the tool, please observe the safety precautions below to prevent possible accident or injury.

Warning

Some dust created by power sanding, sawing, grinding, drilling, and other construction activities contains chemicals known [to the State of California] to cause cancer birth defects or other reproductive harm. Some examples of these chemicals are:

- lead from lead-based paints,
- crystalline silica from bricks and cement and other masonry products, and
- arsenic and chromium from chemically-treated lumber.

Your risk from these exposures varies, depending on how often you do this type of work. To reduce your exposure to these chemicals : work in a well ventilated area, and work with approved safety equipment, such as those dust masks that are specially designed to filter out microscopic particles.

GENERAL: TOOLS

Warning

TO OPERATORS

- **Wear proper clothing for the type of work being done.**
Take care to avoid entanglement with the moving parts of the tool with clothing, ties, hair etc. If items become entangled it will cause the operator to be pulled towards the tool and lead to possible cause of accident or injury.
- **Always wear suitable eye protection.**
Vision correction glasses are not safety glasses. Always wear appropriate safety glasses when doing your job.
- **Always wear suitable hearing protection.**
- **Wear respiratory protective equipment (PPE).**
Wear respiratory protective equipment (PPE) when working in an environment where dust particles are generated in operation.
- **Avoid working posture that is too stressful.**
Always ensure a firm footing and well balanced posture.
- **Do not operate the tool if you are too tired.**
- **Never touch any moving parts of the tool when running.**

ABOUT WORK AREA

- **Keep the work area clean.**
Cluttered work areas (e.g. workbench) invite accidents.
- **Carefully select the work area.**
Do not expose tool to rain.
Do not use tool in a wet or soaked area.
See that the work area is adequately illuminated.
- **Never work near inflammable liquid or in a potentially explosive atmosphere.**
- **Keep children away from the work area.**
Keep children and unauthorized people away from the work area to avoid accident or injury.
- **Some tools generate high noise levels.**
Check to be sure that the use of this tool conforms to all local noise regulations.

BEFORE OPERATION

- **Inspect tool before use.**
Before using, check that screws are securely tightened, that any protective cover or guard is securely in place, other parts are free from damage and that the tool runs as it should.
Check that moving parts are properly adjusted for positioning and tightened, that parts are free from damage and properly mounted, and that all other parts are in good condition for normal operation.
Should you find any damage to the protective cover or other part, replace it in accordance with the Operation Manual. If there are no instructions in the Manual, please contact the sales agent through which you have purchased your tool or an authorized dealer near you for repair.
Likewise, if a switch failure occurs, contact sales agent through which you have purchased your tool or an authorized dealer near you for repair.
Do not use the tool if it does not start or stop with the start/stop switch.
- **Securely mount cutter**
An improperly mounted cutter may fly out, causing possible damage to the tool or injury to the operator.
- **Always remove spanner, wrench, etc., once adjustment has been made with them.**
- **Use a tool appropriate for the application.**
Avoid heavy-duty application that is beyond the capacity of tool.
- **Do not use the tool for purposes other than what it is designed for.**
- **Do not abuse tool.**
Use tool in accordance with the specifications: you'll get the most out of it while ensuring safety.
- **Securely fasten workpiece in place.**
Use a vice or clamp to securely fasten the workpiece

in place. It is much safer this way than holding it in your hand, allowing you to operate the tool with both hands.

ABOUT HANDLING

- **How to store tool.**

When the tool is not used, store it in a dry area and out of reach of children.

- **How to carry tool.**

Do not touch the start switch while the tool is being carried.

- **Do not leave the tool unattended while it is running.**

Turn off the start switch and disconnect the tool from power source. Do not leave the work area until the tool comes to a complete stop.

MAINTENANCE/SERVICE

- **Do not take apart or modify tool.**

Disassembly or modification carried out without the supervision of a qualified or authorized service engineer could result in an accident or injury.

- **Inspect cutting tool and accessories, etc.**

Always check to see that cutting tool and accessories, etc. are in good operating condition without damage or deterioration before you mount them on the tool. Should you find any damage to an accessory or part, please contact sales agent through which you have purchased your tool or an authorized dealer near you for repair.

- **Check parts for damage.**

When you have found damage to accessory or other part, carefully check the damaged part to determine the extent of influence it has upon the functions of the tool – that is, determine whether it can still perform its normal functions.

Check to see that the linkage of the moving parts is OK, that all parts are OK without damage, that they are properly mounted, and that the tool functions normally. Should you find any damage to an accessory or part that may hamper proper functioning of the tool, please contact sales agent through which you have purchased your tool or an authorized dealer near you for repair.

- **Have your tool repaired at an authorized Nitto Service Center.**

For repair or parts replacement, please contact the sales agent through which you have purchased your tool or an authorized dealer near you.

- **Use only Nitto genuine parts.**

Use of improper parts may result in serious occurrence.

To obtain a Nitto genuine part, consult this Manual

or contact the sales agent from which you have purchased your tool directly.

- **Do not detach label or nameplate from tool.**

When a label/nameplate gets damaged, worn or becomes missing, contact the sales agent through which you have purchased your tool or Nitto Kohki Co. Ltd, directly for a replacement.

DISPOSAL

When a tool is taken permanently out of service, it is advised that the tool is disassembled, degreased and parts separated by material and recycled locally in the appropriate manner.

GENERAL: PNEUMATIC TOOLS

Warning

- **Use appropriate air pressure.**

Excessively high air pressure will increase the number of revolutions or strokes causing not only potential premature failure/breakage but could also lead to an unexpected accident or injury.

- **Connect tool to air supply line.**

There are various types of pipes running in a factory in addition to the pneumatic line (such as oxygen, nitrogen, gas and water). For this reason, always ensure that you are connecting to the pneumatic line.

- **Start tool properly.**

Turn the start switch OFF before connecting to the air supply line.

- **Always disconnect the tool from the air supply line before putting on/taking off any accessory and prior to carrying out any maintenance work.**

- **Avoid exposure to exhaust air.**

Pneumatic tool exhaust air contains oil and contaminated moisture. Make sure the exhaust air is not directed towards your face or anyone else within the work area.

- **Keep tool off electricity.**

This pneumatic tool is not electrically insulated. To avoid a potential electric shock do not use where there is a possibility of coming into contact with live electricity.

Caution

- **Handle tool carefully.**

Abusive use of tool could invite failure or accident. Do not throw, drop or shock the tool.

- **Handle air hose carefully.**

Do not carry the tool by the air hose. Do not pull the air hose to disconnect.

INSTRUCTIONS FOR THIS TOOL

About Your Tool

Warning

- **Wear protective glasses and a dustproof mask.**
Operation generates dust and abrasive particles, etc. which may cause eye and/or respiratory injury: Always use PPE (Personal Protective Equipment) for eye and respiratory protection.
- **When you change or adjust the tool or parts, be sure to detach the tool from the air hose.**
- **Never touch the moving parts while in operation.**

Caution

- **Protect yourself from dust and abrasive particles.**
When sanding hot dust and abrasive particles fly off the workpiece: Always wear eye protection glasses, long sleeve protective clothing, gloves (except knitted gloves), foot and leg protection, etc. to protect yourself. Always keep your face away from the sanding surface.

1. USAGE

This is a handheld pneumatic belt sander designed and built to perform sanding operation utilizing a abrasive belt.

2. CHECK THE CONTENTS OF THE PACKAGE

Check the contents and make sure that the tool does not have any damage which may have occurred during transportation. The contents should correspond to the list as follows. In case of damage/missing parts, please contact the sales agent from whom you purchased the tool.

Model	Package Contents	Qty	Check
B-10CL	B-10CL	1set	
	Abrasive Belt Z76#60x10	2(one of them mounted)	
	Abrasive Belt Z76#80x10	1	
	Abrasive Belt Z76#100x10	1	
	Abrasive Belt Z76#120x10	1	
	Hex. Socket Screw Key 1.5	1	
	Hex. Socket Screw Key 4	1	
	Bushing R1/4xNPT1/4	1	
	Instruction Manual	1	
	Declaration of Conformity	1	
	Caution for Use	1	

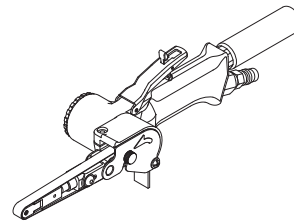

Tool Body

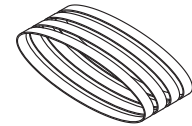

Abrasive Belt



Hex. Socket Screw

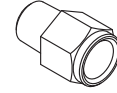

Bushing R1/4xNPT1/4

Model	Package Contents	Qty	Check
B-20CL	B-20CL	1set	
	Abrasive Belt Z76#60x20	2(one of them mounted)	
	Abrasive Belt Z76#80x20	1	
	Abrasive Belt Z76#100x20	1	
	Abrasive Belt Z76#120x20	1	
	Hex. Socket Screw Key 2.5	1	
	Hex. Socket Screw Key 4	1	
	Bushing R1/4xNPT1/4	1	
	Convex Shoe	1	
	Silencer Sub Ass'y	1set	
	Instruction Manual	1	
Declaration of Conformity	1		
Caution for Use	1		

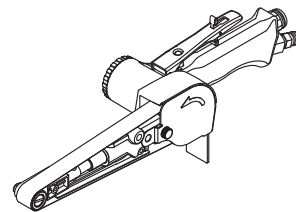

Tool Body

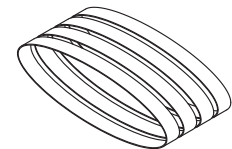

Abrasive Belt

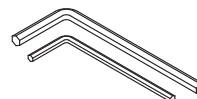

Hex. Socket Screw

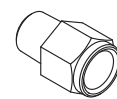

Bushing R1/4xNPT1/4

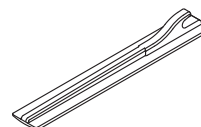

Convex Shoe

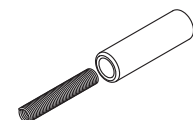

Silencer Sub Ass'y

Model	Package Contents	Qty	Check
B-30CL	B-30CL	1 set	
	Abrasive Belt Z76#60x20	2(one of them mounted)	
	Abrasive Belt Z76#80x20	1	
	Abrasive Belt Z76#100x20	1	
	Hex. Socket Screw Key 5	1	
	Bushing R1/4xNPT1/4	1	
	Silencer Sub Ass'y	1 set	
	Handl Ass'y	1 set	
	Instruction Manual	1	
	Declaration of Conformity	1	
Caution for Use	1		

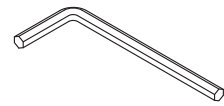

Hex. Socket Screw

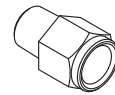

Bushing R1/4xNPT1/4

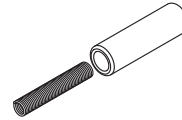

Silencer Sub Ass'y

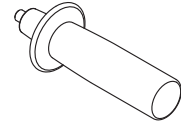

Handl Ass'y

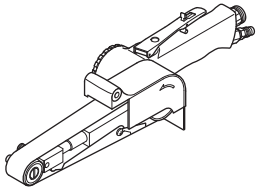

Tool Body

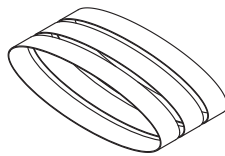

Abrasive Belt

3. NAME OF PARTS

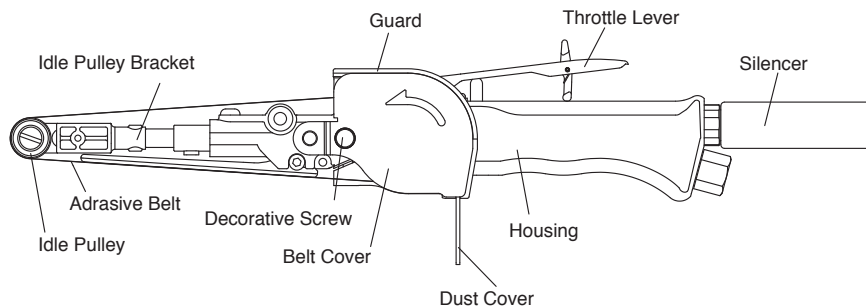

Fig.1

4. AIR SUPPLY

⚠ Caution

- **Draw off drainage before starting operation. If the drainage enters into the tool, it can freeze around the exhaust port of the tool and result in output power reduction.**

4-1. Air Pressure

Adjust air pressure to 0.6MPa (or 6 kgf/cm²) with the air regulator. Lower pressure may result in insufficient performance. Higher pressure may result in premature wornout of parts. It is important to maintain the proper pressure with pressure regulator on air line.

4-2. Air Line (Fig.2)

Use a 9.5 mm (3/8") I.D. air hose between the compressor and the tool. Compressed air comes

to be cooled down and its drain be separated, as soon as the air leaves the compressor. The drain, however, is condensed in the piping, and can enter into the tool mechanism, and may cause malfunction. So, install an air filter and an oiler between the compressor and the tool.

4-3. Oiler

Install an oiler between the compressor and the tool. Use machine oil ISO VG-10 for lubrication and rust prevention. Negligence of the oil supply may cause damages on the tool. Lubricating the tool with high viscosity oil reduces the tool performance.

4-4. Lubrication (Fig.2)

Before starting the tool, disconnect air hose from the tool and supply a few drops of machine oil ISO VG-10 to the air inlet port of the tool. Then reconnect

and make idle running for a few seconds so that the oil should reach every part in the tool.

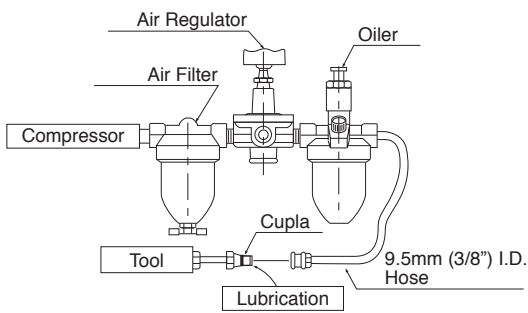

Fig. 2

5. PREPARATION

5-1. Fastening the Guard

⚠ Caution

- No clearance should be allowed between the Housing and the Guard. Any clearance, if there is between them, can cause the Abrasive Belt to come off, resulting in injury to the operator or damage to the equipment or both.

You can set the Guard at any angle you may find best suited for your working posture or the configuration of workpiece. Once you have placed the Guard at a desired angle, tighten the Hex. Socket Head Cap Screw per "A" in Fig. 4 with a Hex. Socket Screw Key. At that time, carefully fasten the Guard so that there is no clearance between the Housing and the Guard.

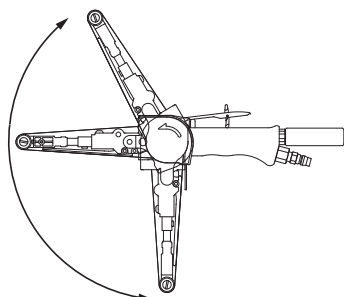
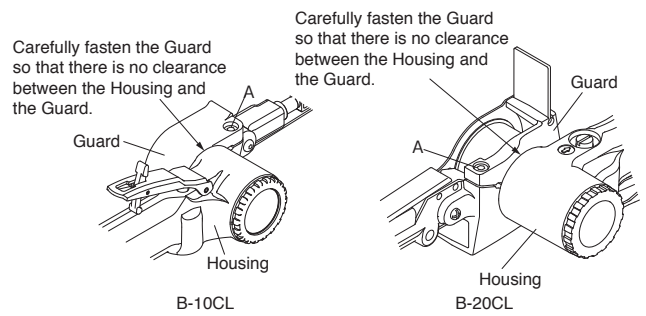

Fig.3



B-10CL

B-20CL

Carefully fasten the Guard so that there is no clearance between the Housing and the Guard.

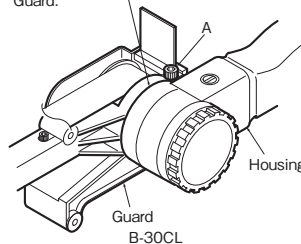

Fig.4

5-2. How To Fix Silencer (B-20CL, B-30CL) (Fig.5)

- Insert the Spring into the Exhaust Cover.
- Insert the Spring into the concave of the Bushing PF3/8 of the Belt Sander.
- Insert the convex of the Exhaust Cover into the groove of the Bushing PF3/8.

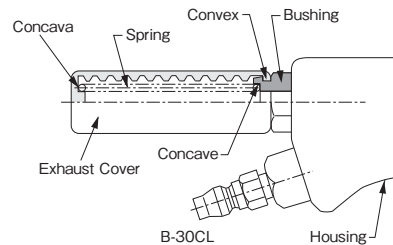
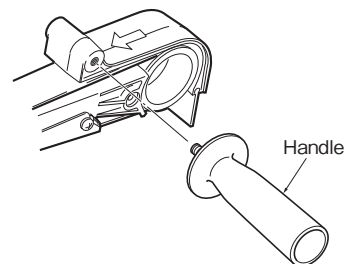

Fig.5

5-3. Attaching the Handle (B-30CL) (Fig.6)

Screw the Handle in the side of the Guard.



B-30CL

Fig.6

6. HOW TO OPERATE THE TOOL

Warning

- When sanding, always wear protective glasses and respiratory protection: Microscopic dust and abrasive particles that fly off the workpiece may cause eye or respiratory injury or both.
- Before you change or adjust the tool or parts, always disconnect the air supply hose.
- Never touch the moving parts in operation.

6-1. Start and Stop (Fig. 7)

- (1) Check to see that the Throttle Lever is in the OFF position.
Then connect the hose to the Belt Sander.
- (2) Holding the Belt Sander:
 - a) Push the Lock Lever down and behind,
 - b) Grasp the Throttle Lever.The Belt Sander starts running.
- (3) When you release the Throttle Lever, it automatically returns to the OFF position.

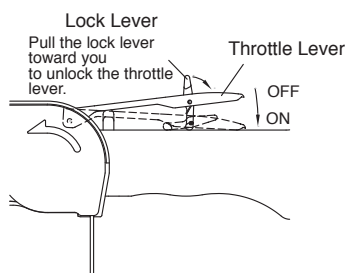

Fig.7

6-2. Adjusting the Rotation Speed (Fig. 8)

The desired number of rotation between maximum Rotation Speed and minimum Rotation Speed is obtained by turning the groove of Valve clockwise or counter clockwise with screwdriver.

Maximum Rotation Speed

Position the groove of Adjust Valve horizontal to main body.

Minimum Rotation Speed

Position the groove of Adjust Valve vertical main body.

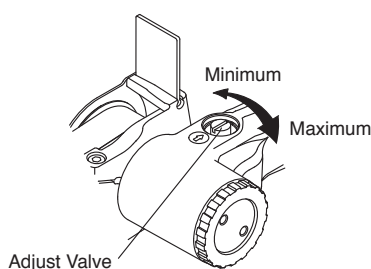

Fig.8

6-3. Tracking Adjustment (Fig. 9)

(1) B-10CL, B-20CL

Loosen the Hex. Socket Set Screw with a Hex. Socket Screw Key as shown in Fig.9, and adjust the adjusting Screw so as the abrasive Belt to run on the center of Idle Pulley. Tighten the Hex. Socket Set Screw with Hex. Socket Screw Key after the adjustment.

You need not make this tracking adjustment when you have an optional 6 mm wide Bracket 6 Assembly (applicable to B-10CL only).

(2) B-30CL

Loosen the Hex. Socket Head Cap Screw, Fig.9 with a Hex. Socket Screw Key.

Turn the Hex. Socket Head Cap Screw clockwise or counterclockwise with the accessory Hex. Socket Screw Key in order to make the abrasive belt run on the center of the idle pulley.

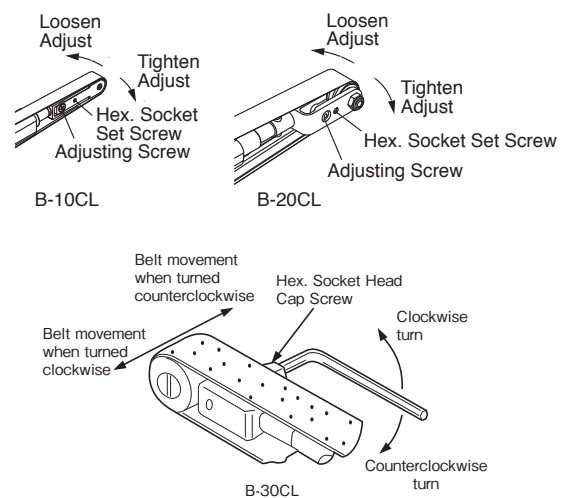

Fig.9

6-4. Sanding Operation

Warning

- Do not press the Abrasive Belt too hard upon the workpiece. If you do so, the Abrasive Belt may break.
- When using a non-woven Belt, do not use the Offset Bracket. If you do so, the Belt may come Off, causing personal injury.

For deburring operation, an Offset Bracket (optional) is to be used.

In this application, the Abrasive Belt will be brought into light contact with the workpiece somewhere in between the Idle Pulley and Offset Bracket.

For Sanding operation, the Offset Bracket will be removed and a Shoe will be used.

The Abrasive Belt will be brought into light contact with the workpiece where the Shoe extends.

6-5. Changing the Abrasive Belt

Caution

- Before servicing, turn the Throttle Lever OFF and disconnect the hose from the Belt Sander.
- When the Abrasive Belt has an arrow marking on its inner face, see to it that you set it to the same direction in which the Belt Sander turns (there is a marking on the Guard), as well. It is dangerous to mount it wrong way for the Abrasive Belt may break prematurely.
- Do not press the Push Button without a Abrasive Belt mounted unless it is absolutely necessary to do so, for it may cause equipment failure.
- When changing the Abrasive Belt, remove dust and abrasive particles from the Drive Pulley area by air blow, etc.

a) B-10CL, B-20CL (Fig.10)

- 1) Loosen the Decorative Screw and turn the Belt Cover.
- 2) Keep pushing the Idle Pulley until the Tension Bar locks.
- 3) Change the Abrasive Belt with a new one. Press the Push Button to release Tension Bar locking.
- 4) Turn the Belt Cover to get it back to where it was. Tighten the Decorative Screw.

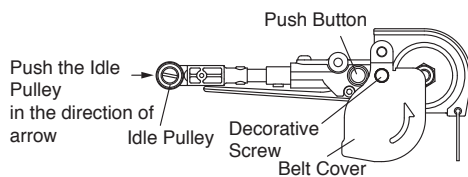

B-10CL, B-20CL

Fig.10

b) B-30CL (Fig.11)

- 1) Loosen the Decorative Screw and turn the Belt Cover.
- 2) Keep pushing the Idle Pulley until the Tension Bar locks.
- 3) Change the Abrasive Belt with a new one. Press the Shoe to release Tension Bar locking.
- 4) Turn the Belt Cover to get it back to where it was. Tighten the Decorative Screw.

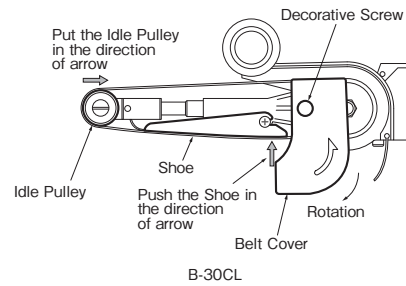

B-30CL

Fig.11

6-6. Replacing the Shoe

a) B-10CL, B-20CL (Fig.12)

Remove the Shoe by loosening Pan Head Screw and replace the Shoe.

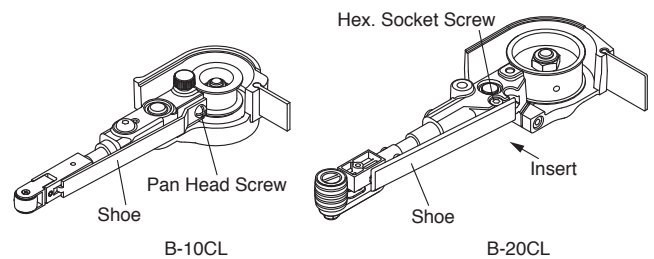

B-10CL

B-20CL

Fig.12

b) B-30CL (Fig.13)

Remove the Belt Cover, Loosen 2pcs, of the M6 cross-recessed Pan Head Screws with a screwdriver and replace the Shoe.

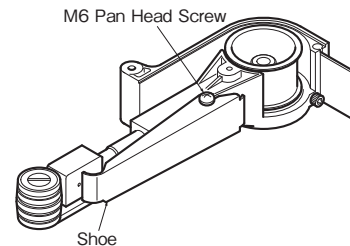

B-30CL

Fig.13

6-7. Replacing the Tension Bar

a) B-10CL, B-20CL (Fig.14)

- 1) Remove the Abrasive Belt. Press the Push Button. The Tension Bar will be unlocked.
- 2) Sufficiently loosen the Key Bolt and pull off the Idle Pulley Bracket while pressing the Push Button.
- 3) When reassembling the Tension Bar, assemble in reverse order.

b) B-30CL (Fig.15)

- 1) Remove the Abrasive Belt, the Belt Cover and the Shoe.

- 2) Sufficiently loosen the Key Bolt and pull off the Idle Pulley Bracket.
- 3) For mounting, adjust the groove on the Idle Pulley Bracket to meet the Key Bolt, insert it into the Guard, put the tip of Key Bolt into the groove and fix it so as the Idle Pulley Bracket not to be pulled off.

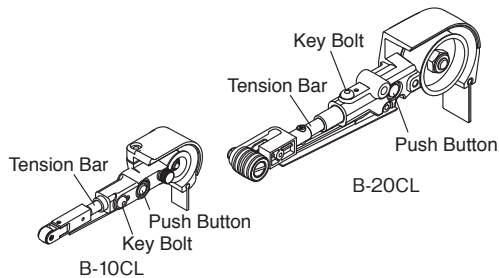

Fig. 14

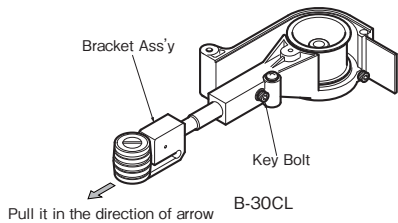

Fig. 15

6-8. Replacing the Idle Pulley

- (1) B-10CL (Fig. 16)

Using a flatblade screwdriver and a Phillips Screwdriver, loosen the Flat Head Screw and pull the Idle Pulley Shaft off.

- (2) B-20CL, B-30CL (Fig. 17)

Using a flatblade screwdriver and a Wrench 10, loosen the Hex. Nut M6 and remove the Idle Pulley B Ass'y. When mounting the Idle Pulley B Ass'y, assemble in reverse order.

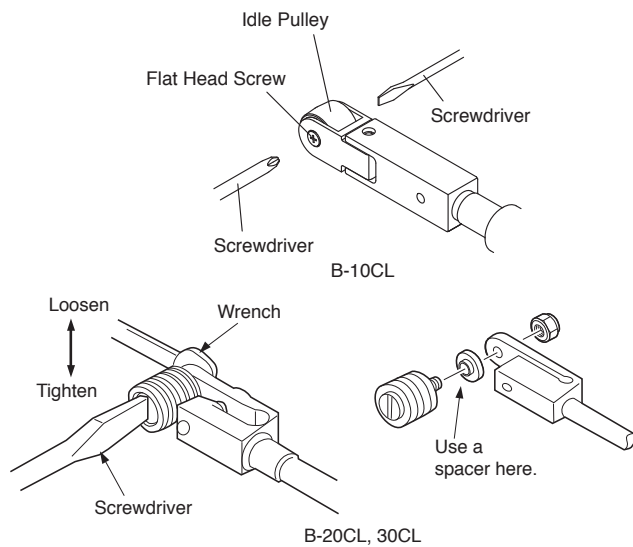

Fig. 16

6-9. Offset Bracket (Optional)

The Offset Bracket is designed to utilize the spring

action of Abrasive Belt, facilitating light-duty sanding applications, such as contoured surface sanding, deburring, etc.

- 1) Following the same procedure as Abrasive Belt replacement, remove the Abrasive Belt.
- 2) Remove the Shoe and mount the Offset Bracket Ass'y. For removal, refer to 6-7 Replacing the Shoe.
- 3) Install the Abrasive Belt and Belt Cover.

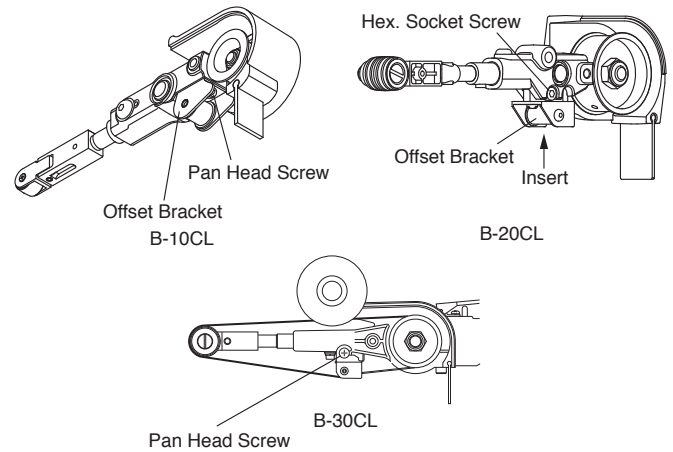

Fig. 17

7. THREAD SIZE OF HOSE FITTING

The product comes with a metal fitting with R(metric) thread. Connect the Bushing R thread x NPT thread in the vinyl bag containing standard accessories, if you would like to have American NPT thread instead.

8. STORAGE AND MAINTENANCE

! Caution

- When tool is not used, store it out of reach of children.

Avoid storing the tool in a location subject to high humidity. If the tool is left as it is used, residual moisture on the inside can cause rusting. Before storing, and after operation, oil the tool at the air inlet with machine oil ISO VG-10 and run it for a short time.

9. ORDERING SERVICE PARTS

For further operational and handling information or for replacement of parts and components, contact the company from whom you purchased the tool or an authorized dealer.

In ordering parts and components give each part number, part name and quantity required.

Use only NITTO genuine parts.

10. OPTIONAL PARTS

In addition to various kinds or grain sizes of abrasive materials and Sanding Belts, we have the following optional items to meet your diversified needs.

- (1) Bracket 6 Ass'y (TB09996) for B-10CL for use with our narrow belt 6 mm in width, best suited for corner grinding or grinding in a narrow space. For mounting and removal, see 5-9 Replacing the Tension Bar.

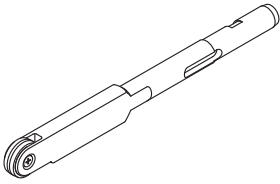

Bracket 6 Ass'y
(TB09996)

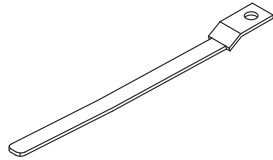

Shoe 6
(TQ10942)

- (2) Offset Bracket Assembly
Offset Bracket 10 Ass'y (TB09997) for B-10CL

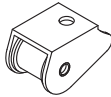

Offset Bracket 20 Ass'y (TB03101) for B-20CL,

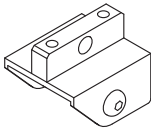

Offset Bracket 30 Ass'y (TB08150) for B-30CL

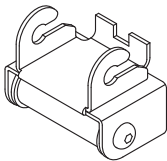

- (3) Finger Pad Ass'y (TB09938) for B-20CL for use

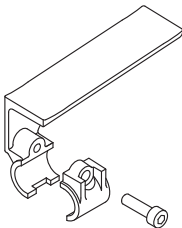

- (4) Idle Pulley Bracket A Ass'y (TB10160) for B-20CL for use.
For mounting and removal, see 6-7 Replacing the Tension Bar.

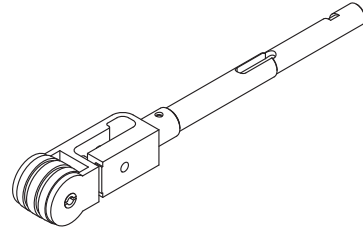

11. EXPLODED DIAGRAM: B-10CL

Warning

This diagram is for your reference only. Do not attempt to service or repair the Tool. Do not take the Tool apart. Contact an authorized Nitto dealer for all service and repair of the Tool.

Improper service and repair can cause accidents and severe injuries.

Never attempt to modify the Tool.

Never attempt service or repair the Tool yourself.

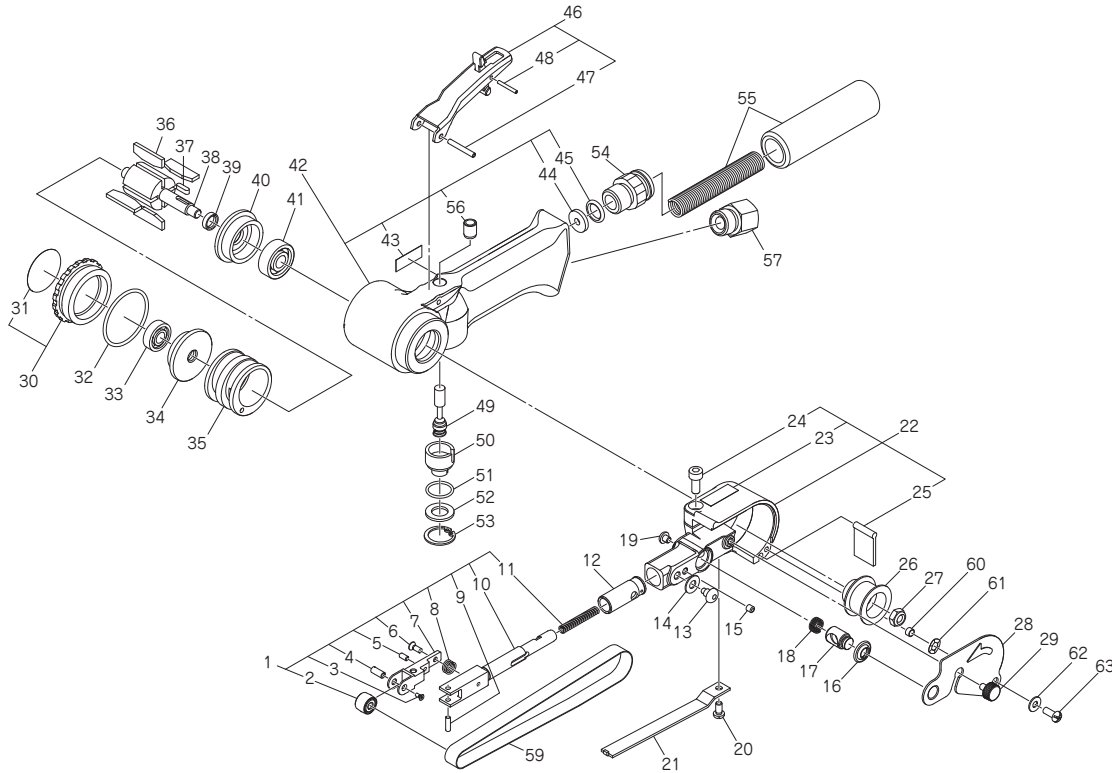

The parts numbers with () are included in the Ass'y parts written above them.

No.	Part No.	Description	Qty	Price
1	TB09920	Bracket 10 Ass'y	1set	
2	(TA99155)	Idle Pulley 10 Sub Ass'y	1set	
3	(TP14455)	Countersunk Head Screw 2X5	1	
4	(TP12431)	Idle Pulley Shaft 10	1	
5	(TP02154)	Hex. Socket Set Screw 3X6	1	
6	(TP00155)	Countersunk Head Screw 3X8	1	
7	(TP14761)	Bracket 10	1	
8	(TP14763)	Spring 0.9X7.5X6.5	1	
9	(TP14798)	Spring Pin 3X10 AW	1	
10	(TQ14673)	Tension Bar 10	1	
11	(TQ14674)	Spring 1.0X4.1X37	1	
12	TQ14665	Guard Insert 10	1	
13	TQ14669	Key Bolt 10	1	
14	LP09810	Washer M5	1	
15	TQ15009	Hex. Socket Set Screw 4X4with Cone Point	1	
16	TQ14667	Push Button Cap 10	1	
17	TQ14666	Push Button 10	1	
18	TQ14668	Spring 0.5X8.5X7	1	
19	TV01534	Pan Head Screw 4X4	1	
20	TP04235	Pan Head Screw 4X8	1	
21	TP14769	Shoe 10	1	
22	TQ14664	Guard 10	1	
23	TP16361	Label Caution	1	
24	TP01945	Hex. Socket Head Cap Screw 5X12	1	
25	TQ10710	Dust Cover	1	
26	TP14916	Drive Pulley	1	
27	TP01924	Hex. Nut M6	1	
28	TQ14672	Belt Cover	1	
29	TQ10712	Decorative Screw	1	
60	TQ15007	Collar	1	
61	TP06576	Wave washer W-5	1	
62	TP07762	Washer M4	1	
63	TQ01526	Pan Head Screw 4X10	1	
30	TB09924	Cap Ass'y	1set	
31	(TQ14732)	Label Model B-10CL	1	
32	TP05531	O-ring S- 36	1	

No.	Part No.	Description	Qty	Price
33	TP06386	Ball Bearing 607ZZ	1	
34	TP12414	End Plate A	1	
35	TP12415	Cylinder	1	
36	TB10008	Blade Ass'y (4pcs/set)	1set	
37	TP10130	Parallel Key Both Ends Round 3X3X10	1	
38	TP12416	Rotor	1	
39	TP06322	Spacer 8X11X3	1	
40	TP12418	End Plate B	1	
41	TP12419	Ball Bearing 628ZZ	1	
42	TB09957	Housing Sub Ass'y	1set	
43	(TQ14731)	Label Warning	1	
44	(TQ14678)	Washer 4.6X14.8X2.6	1	
45	(CP01498)	O-ring P- 11	1	
56	(TQ14780)	Bushing	1	
46	TB01152	Lever Ass'y	1set	
47	(TP00460)	Spring Pin 3X22 AW	1	
48	(TP05498)	Spring Pin 2X16 AW	1	
49	TB10018	Valve Stem Ass'y	1set	
50	TP12405	Adjust Valve	1	
51	TP12407	O-ring S- 15	1	
52	TP12406	Washer 10.5X17.9X1.6	1	
53	CP00987	Internal Retaining Ring C-18	1	
54	TP10005	Bushing PF 3/8	1	
55	TA96323	Silencer Sub Ass'y	1set	
57	TP00857	Bushing M16XPT1/4	1	
58	-	Abrasive Belt #60x10	1	

Accessories

No.	Part No.	Description	Qty	Price
	TP02236	Bushing PT1/4xNPT1/4	1	
	TP14797	Hex. Socket Screw Key 1.5	1	
	TP01939	Hex. Socket Screw Key 4	1	
	-	Abrasive Belt #60x10	1	
	-	Abrasive Belt #80x10	1	
	-	Abrasive Belt #100x10	1	
	-	Abrasive Belt #120x10	1	
58	TQ14733	Instruction Manual	1	

12. EXPLODED DIAGRAM: B-20CL

Warning

This diagram is for your reference only. Do not attempt to service or repair the Tool. Do not take the Tool apart. Contact an authorized Nitto dealer for all service and repair of the Tool.

Improper service and repair can cause accidents and severe injuries.

Never attempt to modify the Tool.

Never attempt service or repair the Tool yourself.

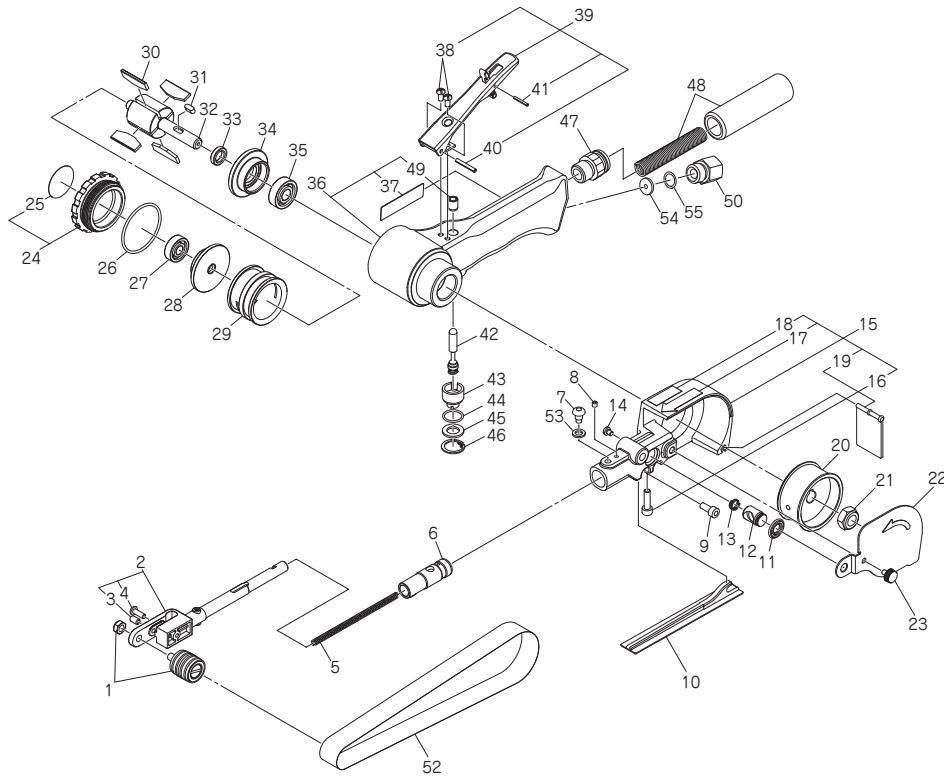

The parts numbers with () are included in the Ass'y parts written above them.

No.	Part No.	Description	Qty	Price
1	TA90514	Idle Pulley B Ass'y	1set	
2	TB09931	Idle Pulley Bracket B Sub Ass'y	1set	
3	(TP06258)	Hex. Socket Set Screw 5x8 with Flat Point	1	
4	(TP16196)	Hex. Socket Head Button Screw 4X12	1	
5	TQ14693	Spring 1.2X3.8X109	1	
6	TQ14686	Guard Insert 20	1	
7	TQ14688	Key Bolt 20	1	
53	TQ14824	Washer M6 6.4X11.5X1.6	1	
8	TQ14689	Hex. Socket Set Screw 4X5with Cone Point	1	
9	TP00200	Hex. Socket Head Cap Screw 5X8	1	
10	TQ15025	Shoe 20	1	
11	TQ14695	Push Button Cap 20	1	
12	TQ14694	Push Button 20	1	
13	TQ14696	Spring 0.6X8.6X7.5	1	
14	TV01534	Pan Head Screw 4X4	1	
15	TB09933	Guard 20 Sub Ass'y	1set	
16	(TP01934)	Hex. Socket Head Cap Screw 5X18	1	
17	(TP16360)	Label Rotation	1	
18	(TP16361)	Label Caution	1	
19	(TQ14691)	Dust Cover 20	1	
20	TQ11617	Drive Pulley	1	
21	TP01918	Hex. Nut M6x1.25	1	
22	TQ14687	Belt Cover 20	1	
23	TQ02418	Decorative Screw	1	
24	TB09964	Cap Ass'y	1set	
25	(TQ14735)	Label Model B-20CL	1	
26	TQ14856	O-ring S- 42	1	
27	TP00468	Ball Bearing 608ZZ	1	
28	TQ14819	End Plate A	1	
29	TQ14822	Cylinder	1	
30	TB10009	Blade Ass'y(4pcs/set)	1set	
31	TP00502	Parallel Key 4X4X 9.5	1	
32	TQ14820	Rotor	1	
33	TP01912	Spacer	1	

No.	Part No.	Description	Qty	Price
34	TQ14821	End Plate B	1	
35	TQ15012	Ball Bearing 6000ZZ LP03	1	
36	TB09963	Housing Sub Ass'y	1set	
37	(TQ14731)	Label Warning	1	
49	(TQ14780)	Bushing	1	
38	TP06290	Pan Head Screw 4X8	2	
39	TB01793	Lever Ass'y	1set	
40	(TP00460)	Spring Pin 3X22 AW	1	
41	(TP05498)	Spring Pin 2X16 AW	1	
42	TB10019	Valve Stem Ass'y	1	
43	TP12405	Adjust Valve	1	
44	TP12407	O-ring S- 15	1	
45	TP12406	Spacer 10.5X17.9X1.6	1	
46	CP00987	Internal Retaining Ring C-18	1	
47	TP10005	Bushing PF 3/8	1	
48	TA96323	Silencer Sub Ass'y	1	
54	TQ15013	Spacer 3.1X14X2	1	
55	CP21038	O-ring P-10A	1	
50	TP00857	Bushing M16XPT1/4	1	
52	-	Abrasive Belt #60x20	1	

Accessories

No.	Part No.	Description	Qty	Price
	TP02236	Bushing PT1/4xNPT1/4	1	
	TP04305	Hex. Socket Screw Key 2.5	1	
	TP01939	Hex. Socket Screw Key 4	1	
52	-	Abrasive Belt #60x20	1	
	-	Abrasive Belt #80x20	1	
	-	Abrasive Belt #100x20	1	
	-	Abrasive Belt #120x20	1	
	TQ14708	Convex Shoe	1	
TQ14733	Instruction Manual	1		

13. EXPLODED DIAGRAM: B-30CL

Warning

This diagram is for your reference only. Do not attempt to service or repair the Tool. Do not take the Tool apart. Contact an authorized Nitto dealer for all service and repair of the Tool.

Improper service and repair can cause accidents and severe injuries.

Never attempt to modify the Tool.

Never attempt service or repair the Tool yourself.

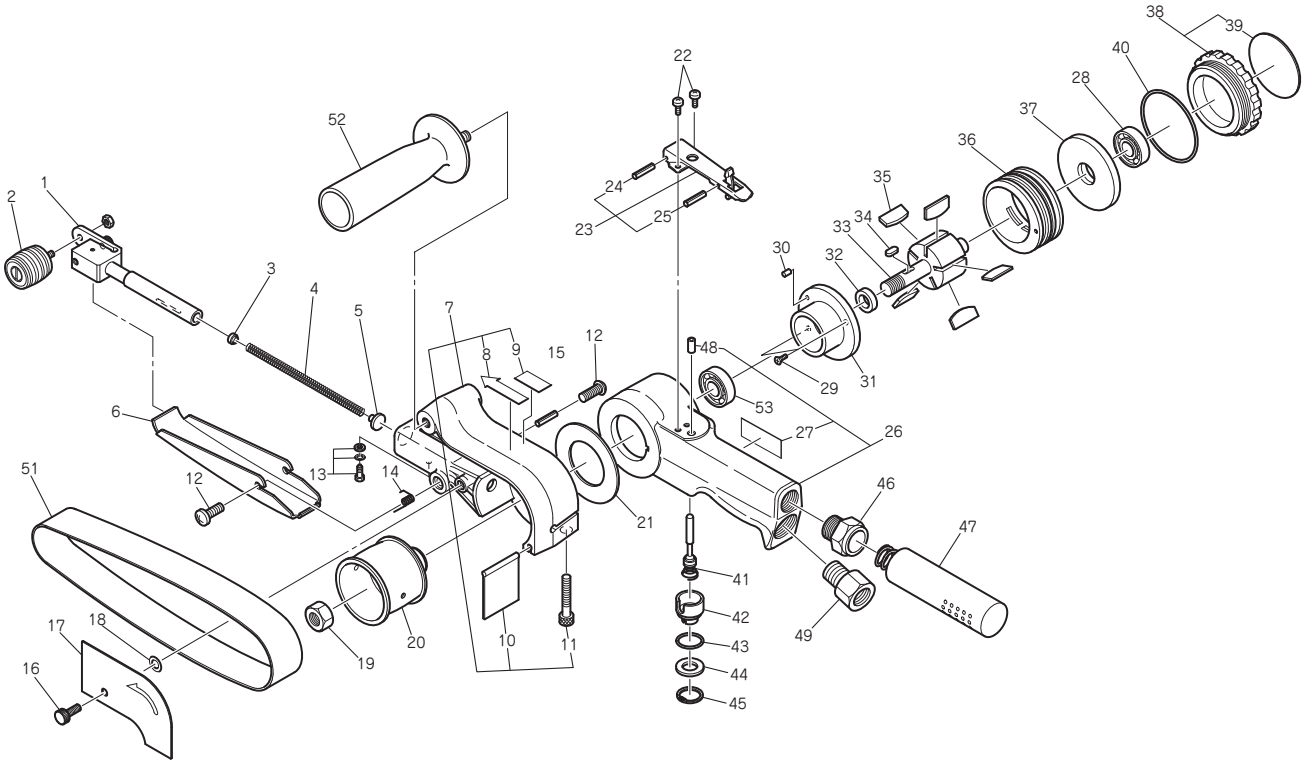

The parts numbers with () are included in the Ass'y parts written above them.

No.	Part No.	Description	Qty	Price
1	TA91524	Tension Bar Ass'y	1set	
2	TA91522	Idle Pulley Ass'y	1set	
3	TP04048	Spring Retainer A	1	
4	TP04047	Tension Spring	1	
5	TP04062	Spring Retainer B	1	
6	TQ11881	Shoe	1	
7	TB09947	Guard Sub Ass'y	1set	
8	(TP16360)	Label Rotation	1	
9	(TP16361)	Label Caution	1	
10	(TP04060)	Dust Cover	1	
11	(TP04073)	Hex. Socket Head Cap Screw 6X35	1	
12	TP08132	Pan Head Screw 6X8	2	
13	TA92254	Key Bolt Ass'y	1set	
14	TQ11810	Shoe Spring	1	
15	TQ11997	Parallel Pin 5X16	1	
16	TQ02418	Decorative Screw 5X10	1	
17	TQ14716	Belt Cover	1	
18	TQ04426	Nylon Washer	1	
19	TP04077	Hex.Nut M12X1.5	1	
20	TQ11807	Drive Pulley	1	
21	TP04058	Thrust Washer B 36.2X62X1	1	
22	TP06290	Pan Head Screw 4X8	1	
23	TB01793	Throttle Lever Ass'y	1set	
24	(TP00460)	Spring Pin 3X22 AW	1	
25	(TP05498)	Spring Pin 2X16 AW	1	
26	TB09969	Housing Sub Ass'y	1set	
27	(TQ14731)	Label Warning	1	
48	(TQ14780)	Bushing	1	
53	TQ15011	Ball Bearing 6001ZZ LP03	1	
28	TP00498	Ball Bearing 6001ZZ	1	
29	TQ11986	Hex. Countersunk Head Screw 4X8	2	
30	TP04061	SpringPin 3X6 AW	4	

No.	Part No.	Description	Qty	Price
31	TQ11801	Lower Bearing Case	1	
32	TP04036	Spacer	1	
33	TP04032	Rotor	1set	
34	TP00502	Parallel Key Both Ends Round 4X4X9.5	1	
35	TB10010	Blade Ass'y (5pcs/set)	1set	
36	TP04031	Cylinder	1	
37	TP04035	Upper Bearing Case	1	
38	TB09970	Cap Ass'y	1set	
39	(TQ14736)	Label Model B-30CL	1	
40	TQ11806	O-Ring AS568A-034	1	
41	TA93925	Valve Stem Ass'y	1set	
42	TP12405	Adjust Valve	1	
43	TP12407	O-Ring S- 15	1	
44	TP12406	Spacer 10.5X17.9X1.6	1	
45	CP00987	Internal Retaining Ring C- 18	1	
46	TP10005	Bushing PF 3/8	1	
47	TA96323	Silencer Ass'y	1set	
49	TP00857	Bushing M16XPT1/4	1	
51	-	Abrasive Belt #60x20	1	

Accessories

No.	Part No.	Description	Qty	Price
52	TB08265	Handle Ass'y	1set	
	TP02236	Bushing PT1/4xNPT1/4	1	
	TP04004	Hex. Socket Screw Key 5	1	
51	-	Abrasive Belt Z76X # 60X30	1	
	-	Abrasive Belt Z76X # 80X30	1	
	-	Abrasive Belt Z76X #100X30	1	
	TQ14733	Instruction Manual	1	

Overseas Affiliates / Offices
NITTO KOHKI U.S.A., INC.

 46 CHANCELLOR DRIVE, ROSELLE,
IL 60172 U.S.A.

TEL: +1-630-924-9393 FAX: +1-630-924-0303

NITTO KOHKI EUROPE CO., LTD.

 UNIT A5, LANGHAM PARK INDUSTRIAL ESTATE,
MAPLE ROAD, CASTLE DONINGTON,
DERBYSHIRE DE74 2UT, U.K.

TEL: +44-1332-653800 FAX: +44-1332-987273

NITTO KOHKI EUROPE GMBH

 GOTTLIEB-DAIMLER-Str. 10,
D-71144 STEINENBRONN, GERMANY

TEL: +49-7-157-22436 FAX: +49-7-157-22437

NITTO KOHKI CO., LTD., SINGAPORE BRANCH

 10 UBI CRESCENT #01-62,
UBI TECHPARK LOBBY D, SINGAPORE 408564,

TEL: +65-6227-5360 FAX: +65-6227-0192

NITTO KOHKI AUSTRALIA PTY. LTD.

 77 BRANDL ST., BRISBANE TECHNOLOGY PARK,
EIGHT MILE PLAINS QLD 4113 AUSTRALIA

TEL: +61-7-3340-4600 FAX: +61-7-3340-4640

NITTO KOHKI CO., LTD.,
BANGKOK REPRESENTATIVE OFFICE

 M&A BUSINESS CENTER 38Q. HOUSE CONVENT BLDG.,
7TH FLOOR, UNIT 7A, CONVENT RD., SILOM, BANGRAK,
BANGKOK 10500 THAILAND

TEL: +66-2-632-0307 FAX: +66-2-632-0308

NITTO KOHKI (SHANGHAI) CO., LTD.

 ROOM1506, SUITE C, ORIENT INTERNATIONAL PLAZA,
NO85 LOUSHANGUAN ROAD, SHANGHAI, 200336, CHINA

TEL: +86-21-6415-3935 FAX: +86-21-6472-6957

NITTO KOHKI CO., LTD.,
SHENZHEN REPRESENTATIVE OFFICE

 2005C SHENZHEN ICC TOWER, FUHUASANLU 168,
FUTIAN DISTRICT, SHENZHEN, GUANGDONG, 518048 CHINA

TEL: +86-755-8375-2185 FAX: +86-755-8375-2187

EC DECLARATION OF CONFORMITY

We hereby declare that the following our product conforms with the essential health and safety requirements of EU Directives.

Brand Name: NITTO KOHKI

Product: PNEUMATIC BELT SANDER

Model: B-10CL, B-20CL and B-30CL

Serial No: In the case of 6 digits serial number.

X X X X X X

└─ Consecutive numbers (00001~99999)

└─ Last digit (0-9) of year (A.D.)

In the case of 7 digits serial number.

X X X X X X X

└─ Consecutive numbers (00001~99999)

└─ Last two digits (00-99) of year (A.D.)

Manufacturer: NITTO KOHKI Co., Ltd.

9-4, NAKAIKEGAMI 2-CHOME, OHTA-KU, TOKYO, 146-8555, JAPAN

Authorised person to prepare the technical construction file(TCF) in the community:

Masatoshi Ogue

President

NITTO KOHKI EUROPE Co., Ltd.

 UNIT A5, LANGHAM PARK INDUSTRIAL ESTATE, MAPLE ROAD,
CASTLE DONINGTON, DERBYSHIRE DE74 2UT, U.K.

Tel: +44-1332-653800 Fax: +44-1332-987273

Directive: 2006/42/EC Machinery Directive

The above product has been evaluated for conformity with above directives using the following European standards. The technical construction file (TCF) for this product is retained at the above manufacturer's location.

Machinery Directive: EN ISO12100:2010, EN ISO11148-8:2011, others

Sound Pressure/Power Level: EN ISO15744:2008, EN ISO4871:2009

Vibration Level: ISO 20643:2008+A1:2012